

This article was downloaded by:

On: 15 January 2011

Access details: *Access Details: Free Access*

Publisher *Taylor & Francis*

Informa Ltd Registered in England and Wales Registered Number: 1072954 Registered office: Mortimer House, 37-41 Mortimer Street, London W1T 3JH, UK

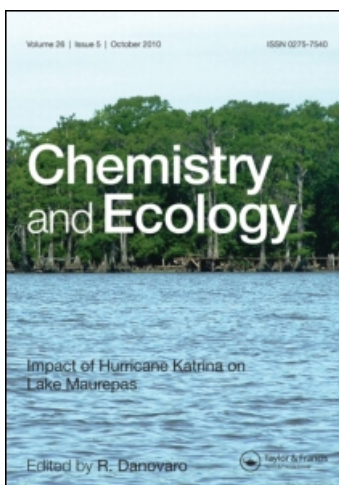

## Chemistry and Ecology

Publication details, including instructions for authors and subscription information:

<http://www.informaworld.com/smpp/title~content=t713455114>

### Heavy Metals in Moss and Bark From Urban Area of Florence: A New Cleaness Procedure for Removing Superficial Particulate Matter

L. Ducceschi<sup>a</sup>; P Cellini Legittimo<sup>b</sup>; L. Morassi Bonzi<sup>c</sup>

<sup>a</sup> Department of Public Health, Epidemiology, and Environmental Analytical Chemistry, University of Florence, <sup>b</sup> Department of Pharmaceutical Sciences, University of Florence, Florence, Italy <sup>c</sup>

Department of Plant Biology, Laboratory of Cytology, University of Florence, Florence, Italy

**To cite this Article** Ducceschi, L. , Legittimo, P Cellini and Bonzi, L. Morassi(1999) 'Heavy Metals in Moss and Bark From Urban Area of Florence: A New Cleaness Procedure for Removing Superficial Particulate Matter', *Chemistry and Ecology*, 16: 2, 119 – 141

**To link to this Article: DOI:** 10.1080/02757549908037642

**URL:** <http://dx.doi.org/10.1080/02757549908037642>

PLEASE SCROLL DOWN FOR ARTICLE

Full terms and conditions of use: <http://www.informaworld.com/terms-and-conditions-of-access.pdf>

This article may be used for research, teaching and private study purposes. Any substantial or systematic reproduction, re-distribution, re-selling, loan or sub-licensing, systematic supply or distribution in any form to anyone is expressly forbidden.

The publisher does not give any warranty express or implied or make any representation that the contents will be complete or accurate or up to date. The accuracy of any instructions, formulae and drug doses should be independently verified with primary sources. The publisher shall not be liable for any loss, actions, claims, proceedings, demand or costs or damages whatsoever or howsoever caused arising directly or indirectly in connection with or arising out of the use of this material.

# HEAVY METALS IN MOSS AND BARK FROM URBAN AREA OF FLORENCE: A NEW CLEANNESS PROCEDURE FOR REMOVING SUPERFICIAL PARTICULATE MATTER

L. DUCCESCHI<sup>a</sup>, P. CELLINI LEGITTIMO<sup>b,\*</sup>  
and L. MORASSI BONZI<sup>c</sup>

<sup>a</sup> Department of Public Health, Epidemiology, and Environmental  
Analytical Chemistry, University of Florence;

<sup>b</sup> Department of Pharmaceutical Sciences, University of Florence, via Gino  
Capponi 9, 50121 Florence, Italy; <sup>c</sup> Department of Plant Biology, Laboratory  
of Cytology, University of Florence, via G. La Pira 4, 50121 Florence, Italy

(Received 27 July 1998; In final form 17 August 1998)

*Hypnum cupressiforme* epiphytic moss and tree bark (elm and holm oak) samples have been collected in three sites of the city of Florence in the period 1995–1998. Lead, zinc, copper, and cadmium were determined by differential pulse anodic stripping voltammetry (DPASV) in about 200 samples collected at different heights above ground. A new clean-up procedure by nitrogen jet has been followed and its efficiency has been also verified by electron microscopy (SEM and ESEM techniques). Lead median contents in moss and bark samples fall within the ranges of 0.052–0.86 and 0.20–1.30  $\mu\text{moles g}^{-1}$  (dry weight), resulting values for moss and bark are proportional to the vehicular traffic density. The increasing use of lead-free gasoline has not been followed by a decrease of lead moss concentration.

**Keywords:** Moss; bark; heavy metals; environmental scanning electron microscopy (ESEM); biomonitoring

## INTRODUCTION

The input of elements, among those of heavy metals, into ecosystems due to human activity has become an increasing burden during the last

---

\* Corresponding author.

centuries. Trace elements, even if deposited constantly at small rates over a long period of time, accumulate in the environment and will probably pose an increasing hazard in the future (Smith and Russell Flegal, 1995). Distributions of lead and cadmium were often investigated, probably because of their toxicity and their ubiquitous occurrence in polluted ecosystems. Lead can be used as an indicator of pollution by automobile exhaust fumes, especially in the form of lead bromo-chloride (PbBrCl), whereas cadmium may be taken as a rough measure of the general anthropogenic pollution of the environment. However, this is a far-reaching generalization, since in many places particular elements other than cadmium are polluting the environment (Walkenhorst *et al.*, 1993). Consequently, it is important to develop and to improve a passive long term monitoring technique for trace metals in order to assess the kind and degree of pollution of ecosystems. At this purpose, it is better to use biotic samples (vegetals and animals) rather than abiotic samples (*e.g.*, water, dusts) because pollutants occur in higher concentrations in biological matrices (especially if they are hyper-accumulators), thus simplifying the chemical analyses. Moreover, the use of a biotic sample to monitor trace element deposition in ecosystems is preferred, because it provides more realistic results than conventional wet or dry sampling apparatus. Finally, body burden is related to the bioavailability of pollutants rather than to their total quantities in the environment. The organisms usually integrate the dose received over the time of exposure; therefore, biotically-bound contaminant is also a better representation of risk.

Since biomonitoring of mosses was first introduced by Rühling and Tyler (1968), the use of mosses, lichens, and barks for monitoring of heavy metal deposition from the atmosphere has found wide application (Grodzinska, 1982; Nimis, 1990; Tyler, 1990). Mosses have been used extensively both as bioindicators and as bioaccumulators (Puckett, 1988; Winner, 1988). Bryophytes, having the capacity to accumulate persistent atmospheric pollutants, have been used extensively also to monitor chlorinated pesticides and elements of radioactive fallout (Thomas, 1986; Guillitte *et al.*, 1990; Nagy and Konya, 1991).

Since 1981, moss (*Hypnum cupressiforme*) is used by the Environmental Protection Agency of Bavaria (Germany) as a bioindicator for

atmospheric background pollution (Forster, 1994). For the research project "Survey of the Heavy Metal Deposition in Europe Using Bryophytes as Bioindicators", a preliminary survey was carried out in Italy using the widespread *Hypnum cupressiforme* and *Scleropodium purum* as biomonitors (Bargagli *et al.*, 1994). According to Thoeni and Hertz (1992), it is possible to use the moss *Hypnum cupressiforme* for background monitoring of heavy metal loads in central Europe, but it is important, especially for lead, that the sampling sites are away from the influence of tree canopies and stemflow.

The main anatomic and physiologic characters of bryophytes as heavy metals deposition monitors, as reported in recent literature, are:

- the usual lack of a protective cuticle and a thicker epidermal cell walls, making their tissues easily permeable to water and minerals, including metal ions (Nimis, 1990; Tyler, 1990);
- their tissues (cell wall constituents) have numerous negatively charged groups and act as efficient cation exchangers. There are probably also groups with a special affinity for heavy metal cations (chelating agents). Heavy metal ions are mainly immobilized by the negative charges of the cell walls and only to a limited degree or at a slow rate transported into the cell interior.

Any toxic effects of heavy metals are supposed to be exerted chiefly or exclusively inside the cell. It might be concluded that the exchange complex of the cell walls is often an excellent, though not a perfect barrier, against penetration of heavy metal ions into the sensitive protoplasm of the bryophyte cell (Tyler, 1990). On the other hand, intracellular accumulation of metal rich deposits may act as a detoxification process (Brown and Wells, 1990).

A high surface to volume or weight ratio also favours the trapping of large particles deposited by impaction and/or dry deposition, though wind speed and other site characteristics may influence their efficiency (Clough, 1975). However, in large scale studies, especially those performed in rather dry and barren environments, much of the material suspended in the air is simply soil and rock dust. In relatively uncontaminated areas, total concentrations of these elements in moss may then reflect regional geochemistry rather than man-made emissions. Bargagli *et al.* (1995), for instance, found higher concentrations of lithophilic elements in *Bryum pseudotriquetrum* from

continental Antarctica (a cold desert environment), than in *Hypnum cupressiforme* from remote areas of Italy. Procedures to assess soil contamination and for normalization of total metal contents to the regional soil composition are suggested by Bargagli *et al.* (1995) and Bargagli (1995).

Almost all elements showed maximum concentrations in winter and the dilution effect of the increasing biomass in spring was regarded as the main factor underlying this trend (Markert and Weckert, 1989). The annual production of biomass differs to some extent between species, which limits the use of several species simultaneously in deposition assessment. Species with a low annual productivity (*e.g.*, *Hypnum cupressiforme*) usually have higher tissue concentrations of heavy metals than species with a high productivity (*e.g.*, *Sphagnum magellanicum*) (Tyler, 1990).

Studies about the uptake of metals by epiphytic *Hypnum cupressiforme* concluded that most of the metals originated from the atmosphere and only a little, with the possible exception of potassium, from the tree bark (Rasmussen and Johnsen, 1976; Rasmussen, 1978). Steubing (1982) demonstrated that the position on the trunk of epiphytic mosses has a strong influence on the concentration values of several heavy metals, the highest concentrations being reached at the base of the trunks where the more important factor might be the effect of splashing water, especially in urban areas.

The influence of stemflow on the accumulation of cadmium and lead in epiphytic *Hypnum cupressiforme* was investigated (Schopp-Guth, 1989). Ion contents were the lowest in sections fed by the main flow path. However, due to the large volumes of drainage water, these sections showed the highest amounts of total ion input. Moss samples taken from two separate microhabitats, the main flow path and the section with low drainage, did not differ in cadmium content. In contrast, the uptake of lead by *Hypnum cupressiforme* was more than four times higher in the main flow path.

The use of tree bark as an indicator of the environmental acidification has been performed since 1960 (Walkenhorst *et al.*, 1993). Bark may be used also as a bioaccumulator. Standardization of collecting procedures is extremely important when using tree bark for biomonitoring. Besides this vegetal matrix, stemflow and the proximity to the ground seems to be the most important source of

error. Amount and composition of the downward running water depend on the crown architecture, *i.e.*, the branching system of the tree species as well as on the bark surface structure. Deciduous trees with rough bark should be used (Nimis, 1990). The bulk of substances is assumed to accumulate on the surface and in the outermost dead bark cells where no substantial active or passive translocation of investigated elements into the wood should take place. Such translocation processes depend probably very much on the physico-chemical properties of the elements and the anatomical structure of the bark (Walkenhorst *et al.*, 1993).

Türkan *et al.* (1995) used the moss *Hypnum cupressiforme* and bark of the pine (*Pinus brutia*) for passive monitoring of airborne heavy metal pollution by an iron–steel industry. In this research, samples of moss were taken from open areas in the pine stands, above the ground parts. The results showed that the measured heavy metal concentrations in samples of moss were higher than those in the bark of pine.

Because contradictory results have been reported by several authors about the clean-up procedures of moss and bark samples (Markert and Weckert, 1989; Walkenhorst *et al.*, 1993; Türkan *et al.*, 1995; Bargagli, 1995), in the present paper a new technique of clean-up has been performed. The cleaner efficiency has been verified by electron microscopy observations. Moss and tree bark samples have been collected in a zone of the city of Florence previously investigated (Cellini Legittimo and Benvenuti, 1996) as well as in two different sites of the same city in order to compare the heavy metal contents between the two vegetal matrices, and to obtain a wider general view on distribution pattern of these pollutants in urban areas.

## SAMPLING AND ANALYTICAL PROCEDURES

A first sampling was carried out in April, 1995, after a period of time characterized by frequent meteoric events and low air temperature, in a wider green area at a higher elevation with respect to the town (Viale Galilei, Fig. 1). The estimated traffic level amounts to 2000 vehicles per hour. Twenty-five samples of *Hypnum cupressiforme* moss have been collected on trunks of holm oak (*Quercus ilex*) trees located on both sides of the road, near the edge, from 1.5 metres above ground. In

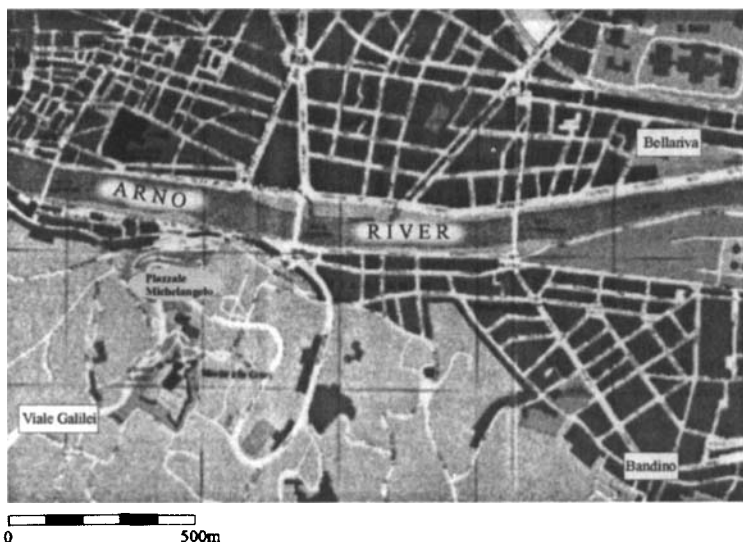

FIGURE 1 Schematic map of investigated area: the sampling sites are shown.

November, 1995, and April, 1998, the moss sampling has been repeated on ten holm oak trees representing the group considered before. On the same trees, moss and outermost bark samples have been collected in February, 1996, at six different heights ranging from 0.5 to 3.0 metres above ground. In this case, only the side of the trunk towards the road has been considered. In addition, on three of the same trunks, a sampling perpendicular to this direction has been performed, and corresponding to 1.5 metres above ground, some bark samples from various depths under the surface of the trunk have been collected. In April, 1996, sampling has been carried out in Bandino and Bellariva areas, located in the south east zone of Florence; the first one is directly exposed to vehicular traffic (about 1200 vehicle per hour) while the second, inside a public park, is about 100 metres from the road (Fig. 1).

*Hypnum cupressiforme* moss and bark samples have been collected on elm (*Ulmus* sp.) trunks at different heights before, ranging from 0.5 to 3.0 metres above ground. All of 150 samples of moss and bark has been collected. The sampling is carried out after a dry span of time (about one month). Points of bark sampling on the tree trunks have been selected immediately near the moss but free from epiphytic organisms in order to avoid any possible sample contamination. On the

other hand, the removal of this epiphytic cover can also change the analytical results. Furthermore, for both moss and bark, the collection was avoided corresponding to the rain tracks on the trunk that represent the preferential path of stemflow.

Usually, the upper green shoots presumably corresponding to the growth of the last one or two years have been removed by stainless scissors. In some samples, the older brown part was also collected. Thin chips (1–3 mm) of the outermost parts of the bark were cut or scraped off from the surface with a stainless steel knife. Plastic gloves have been used to avoid contamination; the samples have been maintained in the laboratory at 4°C in plastic bags.

Initially, all the samples have been carefully sorted to remove rough adhering particulate matter from moss and bark and, in a second step, each sample has been separated into two portions of which one has been subsequently subjected to a new clean-up procedure. Therefore, the sample has been placed in a spheric stainless steel sieve (1 mm mesh) through which nitrogen flowed at one bar pressure during a suitable period of time.

### **Voltammetry Analysis**

Subsequently, samples have been desiccated at 60°C for 48 hours, and finely ground; a careful aliquot of about 100 mg has been mineralized with nitric and perchloric acid (4:1 v/v) Suprapur grade (Merck). Lead, zinc, copper, and cadmium contents have been determined by differential pulse anodic stripping voltammetry (DPASV) at pH 4.5 for acetic buffer. A polarographic analyzer (AMEL, model 473) has been employed for all the measurements. The metal concentrations have been expressed in  $\mu\text{moles g}^{-1}$  of dry weight. The data obtained are mean values of three determinations for each sample.

### **Electron Microscopy**

Transmission Electron Microscopy (TEM), Scanning Electron Microscopy (SEM), and Environmental Scanning Electron Microscopy (ESEM) have been employed for moss study.

For TEM observations, moss leaflets were fixed for 30 minutes in a mixture of 10% glutaraldehyde, 10% acrolein, and 6% *paraformaldehyde* in 0.2 M phosphate buffer (pH 7.2) then washed with the same



buffer solution before post-fixation for 2 hours in 2% buffered osmium tetroxide solution. Dehydration in ethanol and embedding in EponAraldite (Fluka) were carried out by standard procedures. Sections were made with an LKB IV ultramicrotome, stained with uranyl acetate and lead citrate and observed with a Philips EM 201-C working at 80 Kv.

For SEM observations the samples (nitrogen treated and carefully cleaned by hand) were fixed for 30 minutes in a mixture of 10% glutaraldehyde, 10% acrolein and 6% paraformaldehyde in 0.2 M phosphate buffer (pH 7.2) and dehydrated through an alcohol series to absolute alcohol. They were then "critical point dried" using a Balzer CPD 030, mounted on stubs, coated with carbon and examined with a SEM Philips XL20.

For ESEM observations the samples (nitrogen treated and carefully cleaned by hand) were examined in a saturated water vapour environment (4.5 Torr at about 5°C) which, keeping samples fully hydrated all the time, preserves them in original natural state and eliminates the need for sample preparation (fixation and dehydration). The ESEM technology allows in addition, to avoid metallic coating with gold, providing this for exclusive property of GSE imaging and ion charge neutralization generated by water vapour excitation. Consequently, a true image of the sample surface can be observed. The samples were examined in a Philips XL30 lanthanum hexaboride ESEM equipped with a Peltier stage.

### **X-Ray Analysis**

Sample microanalysis was carried out with the same ESEM and by means of an EDAX Compact Detecting Unit (CDU) equipped with a Super Ultra Thin Windows (SUTW) and a fully integrated multi-channel analyzer DX4-i.

## **RESULTS AND DISCUSSION**

### **Superficial Moss Deposits**

Today, it is common to choose a carefully cleaned samples by hand, without washing (Markert and Weckert, 1989; Bargagli *et al.*, 1994;

Bargagli, 1995). This procedure is preferable because contaminating particulate matter cannot be washed off, especially from the moss samples, without the possibility of also leaching materials from the plant tissue. The metal amounts washing out from the sample depends not only on the ratio between moss weight and water volume but it depends also on the initial content of metal and in a different way for each single metal (Cellini Legittimo and Benvenuti, 1996). On the other hand, mosses are generally described as having a negligible cuticle barrier and a high cation exchange capacity and consequently can adsorb and/or absorb a percentage of metal adsorbed on the particulate matter deposited on their surface. Hence, the standardization of washing appears to be quite impossible. The metal content in the superficial moss deposits is depends on weather that affects the windblown dust and its persistence on vegetal matter before the sampling.

Initially, the presence of a cuticle in *Hypnum cupressiforme* moss leaflet has been verified by SEM and TEM observations. As shown in Figure 2, a cell monolayer covered by a continuous film of cutine, wedged among the cells, is visible.

The effect of the nitrogen flow treatment is shown in Figure 3. The ranges of metal amounts removed by this cleaner procedure from moss and bark samples are reported in Table I. The wide ranges of variability can be attributed to different chemical kinds of particulate matter deposited on the sample and, consequently, to a different capacity to bind heavy metals. Referring to the same moss sample, the ratio among the principal chemical elements changes with the microanalysis point chosen, as shown in Figures 4 and 5. Here it is possible to observe, in addition to carbon and oxygen, the relatively higher peaks of aluminium–silicon and calcium–iron. The comparison of these results with the cleaned sample spectrum (Fig. 6) appears to point out as aluminium, silicon, calcium, and iron could be the more representative constituents of particulate matter, and according to the occurrence of argillous minerals and calcium salts in dry deposition of the urban areas considered.

## Moss

The epiphytic moss sampling, carried out in April and November, 1995, and April, 1998, on holm oak trunks, repeats in detail a portion

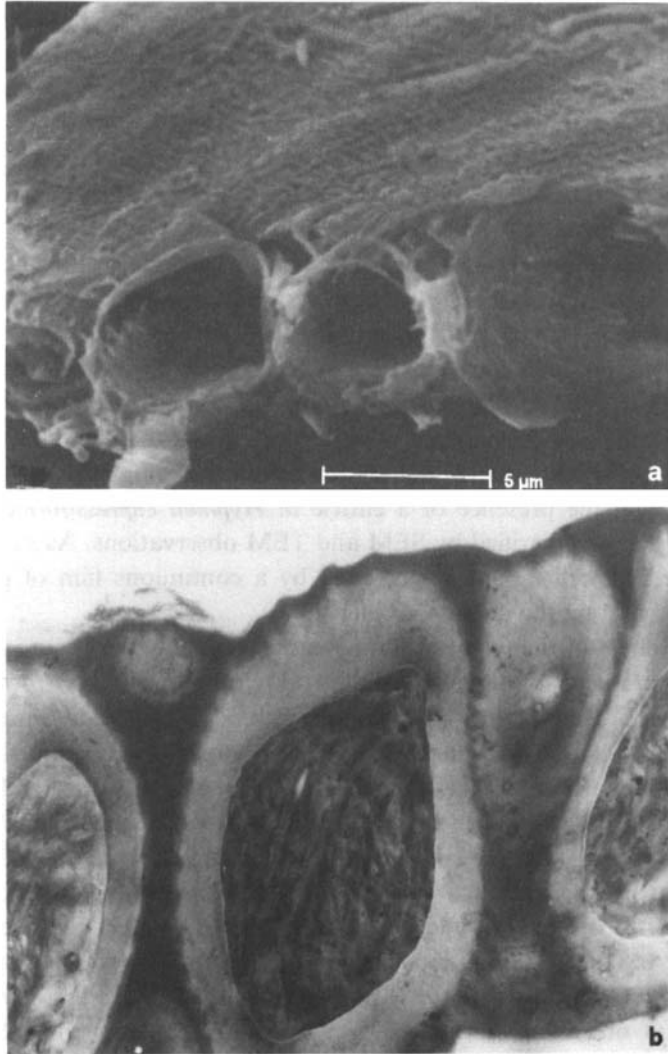

FIGURE 2 (a) Scanning electron microscopic view of *Hymnum cupressiforme* leaflet; (b) the same, transmission electron microscopic view (X 25,000).

of the investigated area in an earlier research (Cellini Legittimo and Benvenuti, 1996). The comparison of results obtained in the different dates of sampling (Tab. II) showed higher concentrations of zinc, copper, and mainly lead in the last period, in spite of the use of

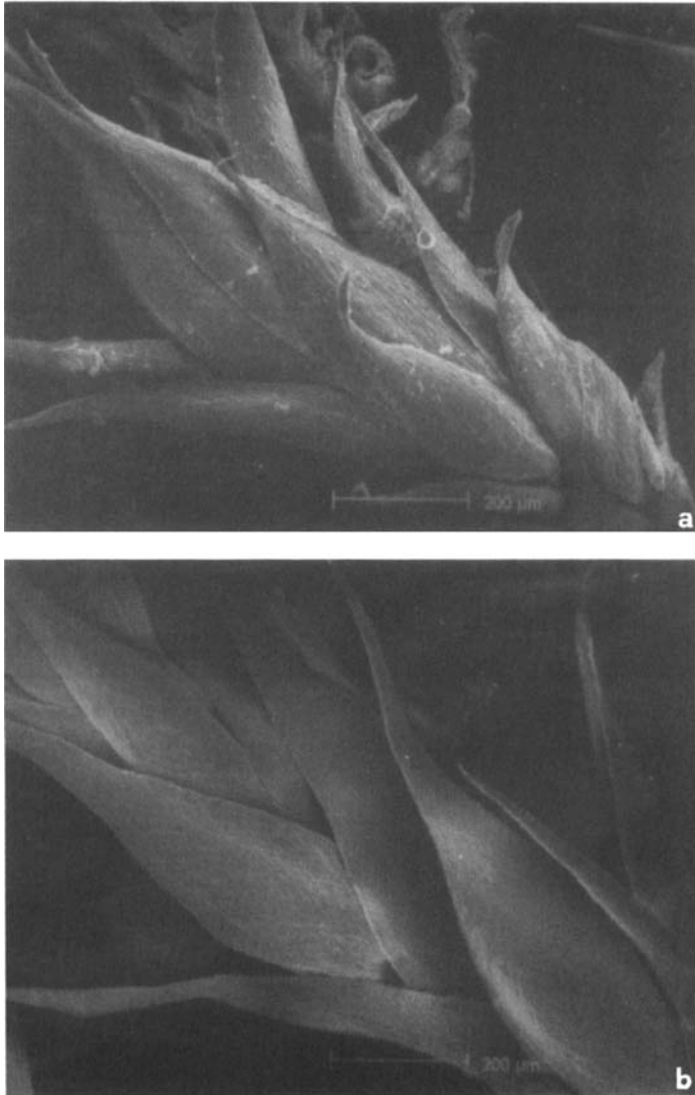

FIGURE 3 (a) Scanning electron microscopic view of untreated *Hypnum cupressiforme* leaflets; (b) the same, cleaned with nitrogen flow.

unleaded gasoline increase. The analytical data obtained from mosses collected on the elm trees in the other two areas (Bellariva and Bandino) are reported in Tables III and IV. There is a considerable

TABLE I Percentage ranges of metal amounts removed by a one bar pressure nitrogen flow from moss and bark samples

	<i>Moss</i>	<i>Bark</i>
	%	%
Pb	5.0-38	3.0-41
Zn	4.0-26	6.0-45
Cu	4.0-41	12-49
Cd	3.0-37	2.0-39

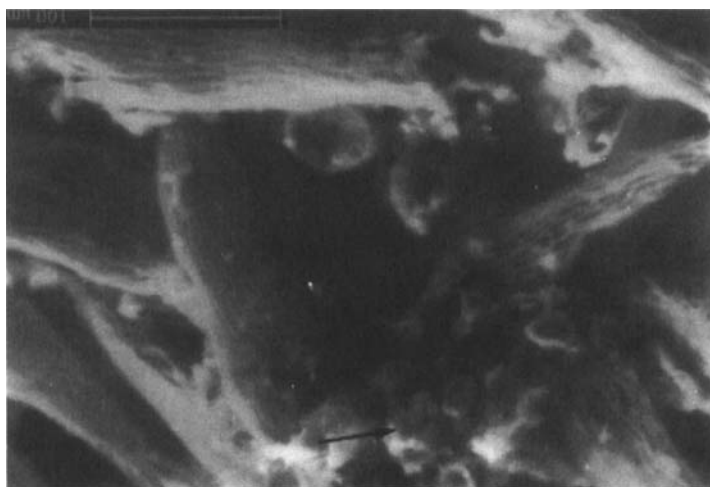
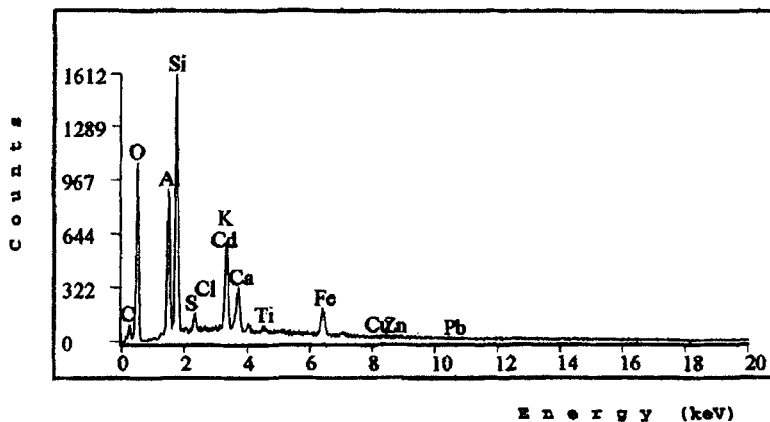

FIGURE 4 Environmental scanning electron microscopic view of superficial particulate matter deposited on *Hypnum cupressiforme* leaflets. X-ray analysis spectrum referred to the indicated point.

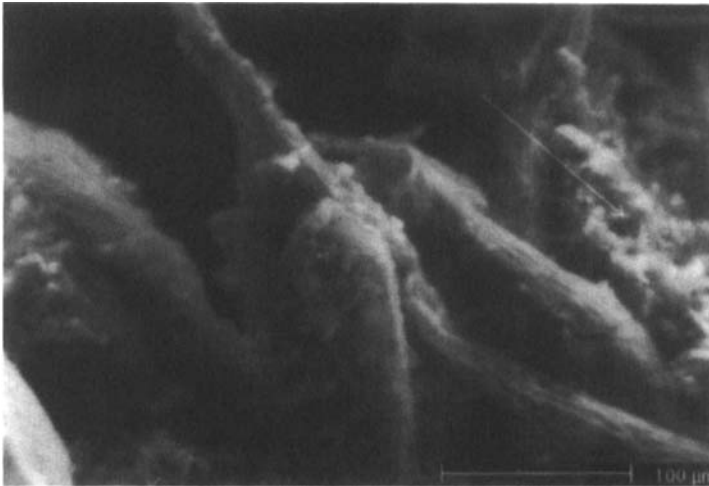
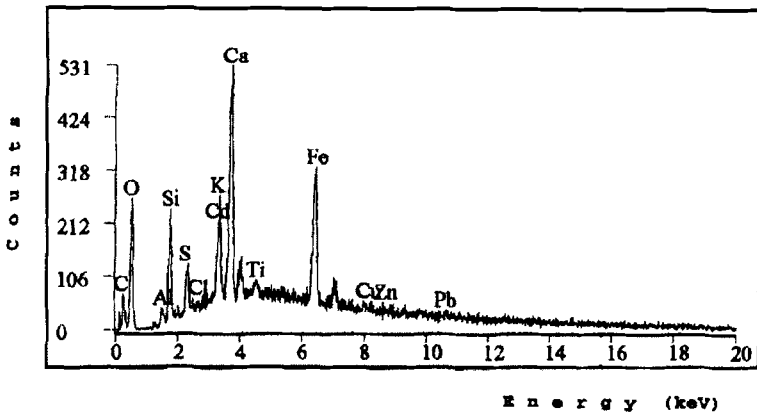

FIGURE 5 Environmental scanning electron microscopic view of superficial particulate matter deposited on *Hypnum cupressiforme* leaflets. X-ray analysis spectrum referred to the indicated point.

difference between metal contents in mosses from Bandino and Bellariva, reflecting different vehicular traffic density. On the other hand, the metal distribution along the trunk does not show remarkable variations in both sites and, according to Karandinós *et al.* (1985), the sample taken at breast height appears the most representative of urban pollution level. Hampp and Höll (1974)

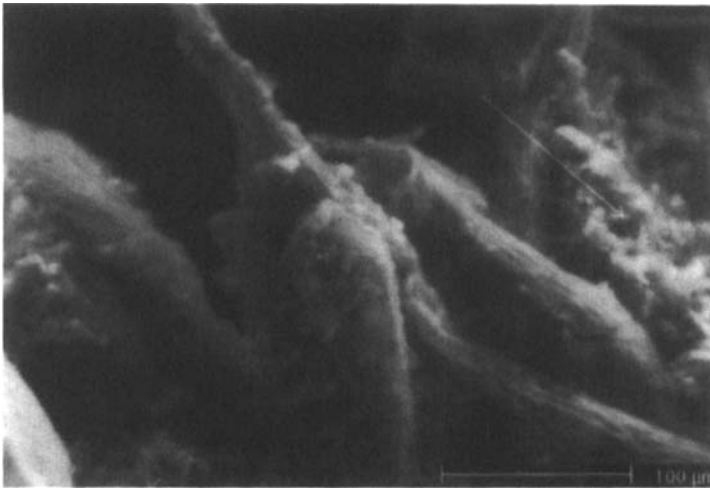
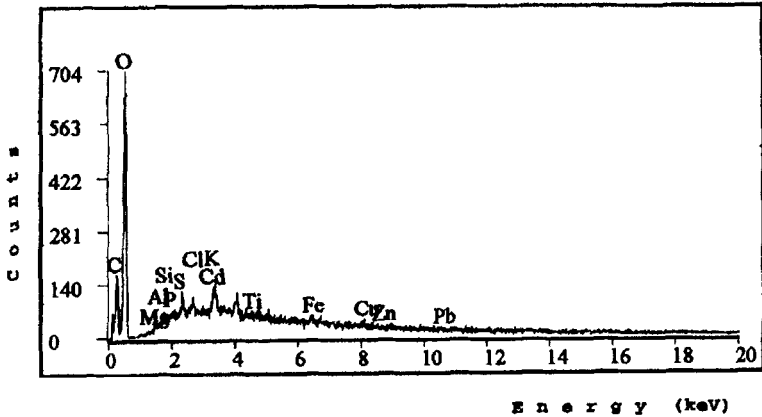

FIGURE 6 Environmental scanning electron microscopic view and X-ray analysis spectrum of *Hyppnum cupressiforme* leaflets in absence of superficial particulate matter.

observed a height-dependent lead distribution and found highest levels at about 150 cm above ground. A different trend can be observed along the holm oak trunks in Viale Galilei (Tab. V) where the evergreen canopy presence may reduce significantly the impact of air transported metal on the part of the trunk protected by the fronds. In fact, the metal contents found at 2.5 and 3 metres height from the soil are clearly lower in respect of the other points of sampling, according to the absence of fronds up to 2 metres height above the ground. In

TABLE II Heavy metal contents in *Hypnum cupressiforme* moss samples collected in different dates on holm oak trunks, at 150 cm height above ground, along the Viale Galilei (Florence)

Metal	July 1993			April 1995			November 1995			April 1998		
	Unwashed samples			Samples cleaned with nitrogen flow			Samples cleaned with nitrogen flow			Samples cleaned with nitrogen flow		
	mean	median	s.d.	mean	median	s.d.	mean	median	s.d.	mean	median	s.d.
Pb, $\mu\text{moles g}^{-1}$	0.42	0.46	0.29	0.40	0.38	0.34	0.40	0.40	0.16	0.70	0.49	0.43
Zn, $\mu\text{moles g}^{-1}$	1.39	1.26	0.52	1.11	0.80	0.70	0.93	0.88	0.37	1.22	1.08	0.48
Cu, $\mu\text{moles g}^{-1}$	0.48	0.49	0.16	0.66	0.67	0.26	0.43	0.33	0.20	0.83	1.72	0.25
Cd, $\text{nmoles g}^{-1}$	3.2	2.5	1.7	4.8	3.6	3.2	4.8	3.6	3.2	5.3	3.2	4.3

TABLE III Heavy metal contents in *Hypnum cupressiforme* moss samples collected on elm trunks from the Bellariva site (Florence)

Height above ground (cm)	Pb			Zn			Cu			Cd		
	mean	median	s.d.	mean	median	s.d.	mean	median	s.d.	mean	median	s.d.
50	0.057	0.052	0.02	0.38	0.41	0.10	0.15	0.15	0.03	1.9	2.0	0.4
100	0.053	0.049	0.03	0.34	0.31	0.09	0.15	0.14	0.03	2.1	2.2	0.4
150	0.056	0.057	0.02	0.36	0.37	0.10	0.15	0.13	0.03	2.0	1.9	0.3
200	0.058	0.055	0.02	0.34	0.34	0.09	0.15	0.16	0.04	2.2	2.2	0.5
250	0.062	0.065	0.03	0.33	0.31	0.05	0.14	0.13	0.03	2.1	2.0	0.6
300	0.060	0.061	0.02	0.31	0.30	0.04	0.14	0.14	0.04	2.5	1.8	0.8



TABLE IV Heavy metal contents in *Hypnum cupressiforme* moss samples collected on elm trunks from the Bandino site (Florence)

Height above ground (cm)	Pb $\mu\text{moles g}^{-1}$		Zn $\mu\text{moles g}^{-1}$		Cu $\mu\text{moles g}^{-1}$		Cd $\text{nmoles g}^{-1}$	
	mean	s.d.	mean	s.d.	mean	s.d.	mean	s.d.
50	0.16	0.02	0.89	0.06	0.19	0.01	3.0	0.7
100	0.16	0.03	0.75	0.12	0.22	0.02	3.1	2.9
150	0.18	0.04	0.76	0.09	0.23	0.04	3.4	0.4
200	0.17	0.02	0.76	0.13	0.25	0.06	2.9	0.5
250	0.15	0.02	0.58	0.18	0.29	0.04	3.2	3.3
300	0.14	0.02	0.51	0.10	0.25	0.01	2.5	2.1

TABLE V Heavy metal contents in *Hypnum cupressiforme* moss samples collected from holm oak trunks along the Viale Galilei (Florence)

Height above ground (cm)	Pb $\mu\text{moles g}^{-1}$		Zn $\mu\text{moles g}^{-1}$		Cu $\mu\text{moles g}^{-1}$		Cd $\text{nmoles g}^{-1}$	
	mean	s.d.	mean	s.d.	mean	s.d.	mean	s.d.
50	0.91	0.16	1.99	0.29	0.92	0.28	3.9	2.1
100	1.01	0.27	2.27	0.20	1.23	0.16	2.9	2.1
150	0.95	0.48	2.35	1.14	1.26	0.26	4.5	2.2
200	0.88	0.63	2.19	0.82	1.31	0.52	4.7	1.7
250	0.44	0.13	1.25	0.33	0.83	0.02	4.7	1.2
300	0.39	0.04	0.98	0.09	0.71	0.09	5.7	1.4

addition, if the sampling is made at the same height from the soil but orthogonally to the first (Fig. 7), different results are obtained. The comparison among Bellariva, Bandino, and Viale Galilei data points out the higher traffic level in the last site and gives evidence that, in addition to lead, zinc and copper are linked, even if partially, with vehicular emissions. At the same time, the zinc/lead ratio may represent a parameter to evaluate the degree of pollution in poorly industrialized urban area. In fact, the range of values of zinc/lead ratio calculated by Tables III, IV, and V data decrease in order of higher traffic density sites (4.8–7.9 for Bellariva, 3.1–5.6 for Bandino, and 1.1–4.3 for Viale Galilei).

### Bark

The heavy metal contents in elm bark samples collected at Bellariva and Bandino are shown in Tables VI and VII, respectively. Lead, zinc, and copper concentrations are always higher than those found in corresponding moss samples. Instead, for cadmium, a similar content in both bioaccumulators can be observed. The range values of zinc/

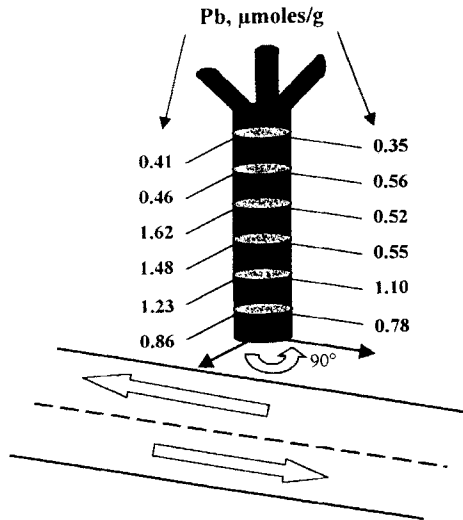

FIGURE 7 Lead amount (3 samples mean) in *Hypnum cupressiforme* moss samples collected on holm oak trunks at different heights ranging from 0.5 to 3.0 metres above ground and according to two orthogonal directions, from Viale Galilei (Florence).

TABLE VI Heavy metal contents in bark samples collected on elm trunks from the Bellariva site (Florence)

Height above ground (cm)	Pb $\mu\text{moles g}^{-1}$		Zn $\mu\text{moles g}^{-1}$		Cu $\mu\text{moles g}^{-1}$		Cd $\text{nmoles g}^{-1}$	
	mean	s.d.	mean	s.d.	mean	s.d.	mean	s.d.
50	0.21	0.12	1.02	0.88	0.27	0.22	2.2	0.19
100	0.26	0.07	0.89	0.77	0.19	0.15	2.1	0.15
150	0.29	0.06	0.93	1.00	0.27	0.19	2.2	0.12
200	0.30	0.27	1.21	1.34	0.34	0.20	2.1	0.30
250	0.40	0.33	1.04	1.11	0.53	0.21	2.7	0.15
300	0.32	0.10	1.47	1.52	0.33	0.29	3.4	0.22

TABLE VII Heavy metal contents in bark samples collected on elm trunks from the Bandino site (Florence)

Height above ground (cm)	Pb $\mu\text{moles g}^{-1}$		Zn $\mu\text{moles g}^{-1}$		Cu $\mu\text{moles g}^{-1}$		Cd $\text{nmoles g}^{-1}$	
	mean	s.d.	mean	s.d.	mean	s.d.	mean	s.d.
50	0.79	0.49	1.78	2.40	0.44	0.51	4.6	0.17
100	0.98	1.07	1.95	1.87	0.56	0.60	3.3	0.26
150	0.90	0.92	1.46	1.45	0.50	0.46	2.6	0.24
200	1.14	0.95	1.92	1.60	0.66	0.65	3.2	0.07
250	1.34	1.30	1.97	1.87	0.61	0.43	3.4	0.32
300	1.31	1.13	1.88	1.91	0.68	0.66	3.4	0.21

lead ratio in barks (2.6–4.8 for Bellariva and 1.4–2.2 for Bandino) are likewise as significant as those found in mosses. An overview of the results obtained is shown in Figure 8, where the four metal concentrations (median) for Bellariva and Bandino are reported. The same trends for each metal in both vegetal matrices can be observed in the two different sites. Consequently, it appears clear that moss and bark can be used for biomonitoring of different urban pollution levels.

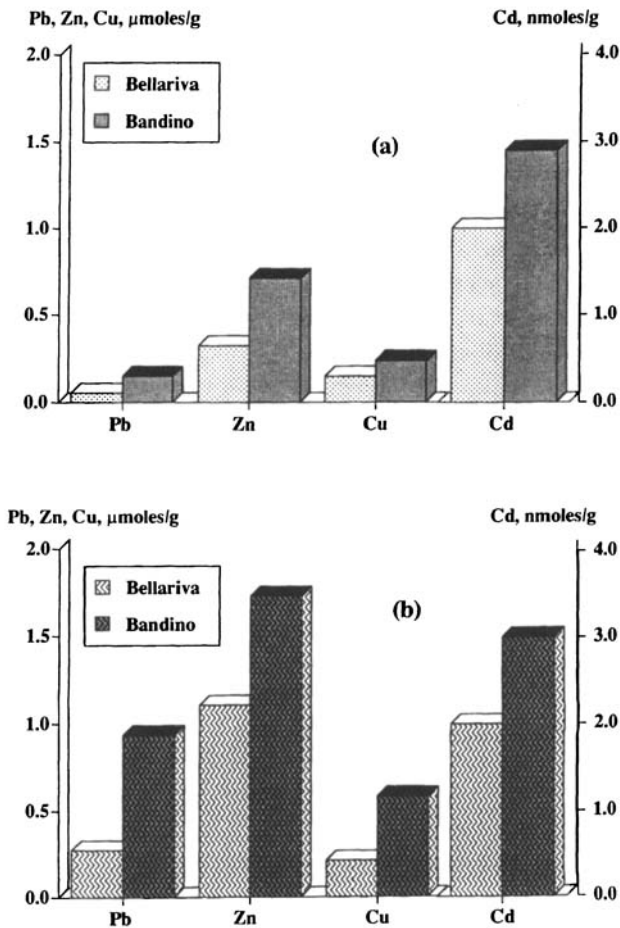

FIGURE 8 Heavy metal concentrations (median) related to moss (a) and bark (b) samples collected in Bellariva and Bandino sites (Florence).

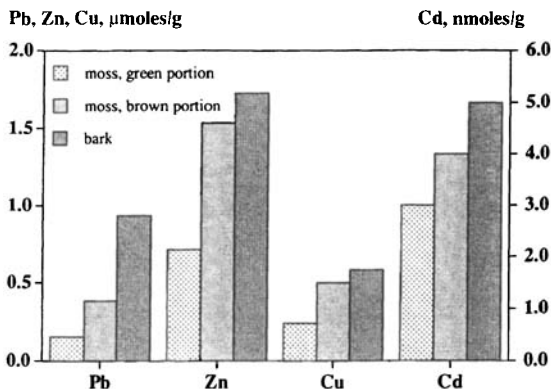

FIGURE 9 Comparison of heavy metal contents (mean values) among moss (green and brownish portion) and bark samples from the Bandino site (Florence).

Previous experiences carried out on holm oak trunks (Cellini Legittimo and Benvenuti, 1996, and following unpublished data) showed only for lead a similar behaviour in respect to moss, while lower values were obtained for zinc. Copper and cadmium contents appear lower or higher alternately in respect to moss values.

Standardization of collecting procedures is extremely important for a correct comparison among different vegetal matrices. In fact, the metal contents in the brownish part of moss has resulted in higher levels in relation to green part but lower than bark, except cadmium (Fig. 9). On the other hand, the bark thickness must be taken into account, because different metal concentrations have been found in bark samples from various depths under the surface of the trunk. In the depth range 0–10 mm, a logarithmic decrease for lead has been verified. Linear decrease has been observed for zinc and copper, while cadmium content remains nearly constant.

## CONCLUSIONS

The cleaning pretreatment of samples by nitrogen jet used in the present study appears the most suitable to remove particulate matter present on moss surface. At the same time, this procedure avoids the

risk of contamination due to the sample washing. Particularly, environmental scanning electron microscopy microanalysis has verified the presence of different chemical kind of deposits present in different portions of the same moss leaflet. The removal of this superficial matter, that can adsorb and/or absorb heavy metals, allows a true evaluation of the metal accumulated in moss. The heavy metal contents, in particular lead, found in the moss are proportional to the vehicular traffic density in the neighbourhood in which samples were collected. However, unexpected higher lead moss concentrations in comparison with the data referring to the period 1993–1998, have been obtained in the last year, in spite of increasing use of lead-free gasoline.

Finally, the highest metal contents recovered in elm bark samples, together more frequent occurrence of this vegetal matrix, appear to point out the better use of the bark as a bioaccumulator for biomonitoring purposes.

### *Acknowledgment*

The authors are indebted to Philips General Optics and particularly to its General Manager Mr. Alberto Tinti for having offered them the chance to use the ESEM of Philips Laboratories in Monza and Roma, and to Dr. Andrea Valdrè, Product Specialist, for his advice and help in the observations and X-ray analysis. Excellent technical assistance by Mr. Patrizio Nuti and Mr. Gilberto Montori, is greatly appreciated.

### *References*

- Bargagli, R. (1995) The elemental composition of vegetation and the possible incidence of soil contamination of samples. *The Science of the Total Environment*, **176**, 121–128.
- Bargagli, R., Battisti, E., Cardaioli, E., Formichi, P. and Nelli, L. (1994) La deposizione atmosferica di elementi in tracce in Italia. *Inquinamento*, **2**, 48–58.
- Bargagli, R., Brown, D. H. and Nelli, L. (1995) Metal biomonitoring with mosses: procedures for correcting for soil contamination. *Environ. Pollut.*, **89**, 169–175.
- Brown, D. H. and Wells, J. M. (1990) The extracellular and intracellular uptake of inorganic chemicals by bryophytes. In: *Bryophytes, Their Chemistry and Chemical Taxonomy*. Zinsmeister, H. D. and Mues, R. (Eds.), Clarendon Press, Oxford, pp. 299–318.

- Cellini Legittimo, P. and Benvenuti, R. (1996) Heavy metals in epiphytic mosses: an experience in Florence. *Chemistry and Ecology*, **13**, 39–49.
- Clough, W. S. (1975) The deposition of particles on moss and grass surfaces. *Atmospheric Environment*, **9**, 1113–1119.
- Forster, E. M. (1994) Optimization of a bioindicator-measuring network with the help of geostatistical methods and a geographical information system. *GSF-Ber.*, 14/94, p. 145.
- Grodzinska, K. (1982) Monitoring of air pollutants by mosses and tree bark. In: *Monitoring of Air Pollutants by Plants. Methods and Problems*, Steubing, L. and Jaeger H. J. (Eds.), Junk, The Hague, pp. 33–42.
- Guillitte, O., de Brabant, D. and Gasia, M. C. (1990) Use of mosses and lichens for the evaluation of the radioactive fallout, deposits and flows under forest cover. *Mem. Soc. R. Belg.*, **12**, 89–99.
- Karandinos, H. G., Papakostidis, G. K. and Fantinou, A. A. (1985) Lead assessment in Aleppo pine trees from the greater Athens region. In: *Heavy Metals in the Environment*, International Conference, Athens, September, 1985. Lekkas, T. D. (Ed.), CEP-Consultants LTD, Edinburgh, pp. 602–606.
- Markert, B. and Weckert, V. (1989) Use of *Polytrichum formosum* (moss) as a passive biomonitor for heavy metal pollution (cadmium, copper, lead and zinc). *The Science of the Total Environment*, **86**, 289–294.
- Nagy, N. M. and Konya, J. (1991) Cesium ion uptake by moss (*Hypnum cupressiforme*). *Isotopenpraxis*, **27**, 21–23.
- Nimis, P. L. (1990) Air quality indicators as indices: the use of plants as bioindicators for monitoring air pollution. In: *Proceedings of the Workshop on Indicators and Indices for Environmental Impact Assessment and Risk Analysis*, 3–5 May, Ispra, Italy. Colombo, A. G. and Premazzi, G. (Eds.), pp. 93–126.
- Puckett, K. J. (1988) Bryophytes and lichens as monitors of metal deposition. *Bibl. Lichenol.*, **30**, 231–267.
- Rasmussen, L. (1978) Element content of epiphytic *Hypnum cupressiforme* related to element content of the bark of different species of phorophytes. *Lindbergia*, **4**, 209–218.
- Rasmussen, L. and Johnsen, I. (1976) Uptake of minerals, particularly metals, by epiphytic *Hypnum cupressiforme*. *Qikos*, **27**, 483–487.
- Rühling, A. and Tyler, G. (1968) An ecological approach to the lead problem. *Bot Notiser*, **121**, 321–342.
- Schopp-Guth, A. (1989) Studies of stemflow in beech and its effect on epiphytic mosses (*Hypnum cupressiforme*). *Verh.-Ges. Oekol.*, **17**, 571–576.
- Smith, D. R. and Russell Flegal, A. (1995) Lead in the biosphere: recent trends. *Ambio*, **24**, 21–23.
- Steubing, L. (1982) Problems of bioindication and the necessity of standardization. In: *Monitoring Air Pollutants by Plants. Methods and Problems*. Steubing, L. and Jaeger, H. J. (Eds.), Jaeger, The Hague, pp. 19–27.
- Thoeni, L. and Hertz, J. (1992) Applicability of the moss *Hypnum cupressiforme* for biomonitoring of heavy metals: 1. An investigation of site requirements. In: *Met. Compd. Environ. Life, 4, Sel. Pap. IAEA Workshop Toxic Met. Compd., 4th 1991*, Ernst, M. (Ed.); Haerdi, W., *Sci. Technol. Lett.*, Northwood, UK, pp. 137–151.
- Thomas, W. (1986) Representativity of mosses as biomonitor organisms for the accumulation of environmental chemicals in plants and soils. *Ecotoxicology and Environmental Safety*, **11**, 339–346.
- Türkan, I., Henden, E., Çelik, U. and Kivilcim, S. (1995) Comparison of moss and bark samples as biomonitors of heavy metals in a highly industrialized area in Izmir, Turkey. *The Science of the Total Environment*, **166**, 61–67.
- Tyler, G. (1990) Bryophytes and heavy metals: a literature review. *Botanical Journal of the Linnean Society*, **104**, 231–253.

- Walkenhorst, A., Hagemeyer, J. and Breckle, S. W. (1993) Passive monitoring of airborne pollutants, particularly trace metals, with tree bark. In: *Plants as Biomonitors*, Markert, B. (Ed.). VCH, Weinheim, pp. 523–540.
- Winner, W. E. (1988) Response of bryophytes to air pollution. In: *Lichens, Bryophytes and Air Quality*, Nash III Th. and Wirth, V. (Eds.). Cramer, Berlin-Stuttgart, pp. 141–173.